

©Shutterstock.com



UVGERMI®

ULTRAVIOLETS DE HAUTE TECHNOLOGIE

Treatment solutions for sea water using ultraviolet reactors.

● ○ ● MADE IN FRANCE

16000677_A_FT10

GERMI LD 300 HDPE

> **Flow rate:** from 505 to 810 m³/h

The **GERMI LD 300 HDPE** is specially designed to prevent the development of diseases in aquariums and fish farm ponds by destroying the parasites, bacteria and viruses in the sea water without using chemical substances that are toxic for marine organisms. The HDPE body offers excellent resistance to all corrosive atmospheres.



Warranty: 1 year
After-sales in France

TECHNICAL SPECIFICATIONS

Equipment to treat an average water flow rate from 505 m³/h (at 40 mJ/cm²) to 810 m³/h (at 25 mJ/cm²) with transmittance of 90% over 10 mm.

UV LAMP

Total electrical power: 3,600 Watts (12 lamps)
Germicidal power: 1,380 Watts UVC
Lamp service life: 16,000 hours or 2 years

UV REACTOR

Treatment chamber: HDPE
Input/Output: (PVC) 315 / DN 300
Operating pressure: 6 bars
Bleed valve and drainage valve
1 cap to replace one of the valves
Welded support lugs
Temperature probe

ELECTRICAL CABINET

Dimensions (mm): 1,000 x 750 x 420
Protection rating: IP 52
Power supply: 400 V +N+E / 50-60 Hz
On/off switch /
Lamp operation indicator / Hour counter

ASSOCIATED PRODUCTS

300 W UV lamp: 14000127
Quartz sleeve: 14000089
O-ring: 15000335

OPTIONS

Automatic air bleed /
Digital UV sensor with display / IP65 cabinet

16000677_A_FT10

GERMI LD 300 HDPE

> **Flow rate:** from 505 to 810 m³/h

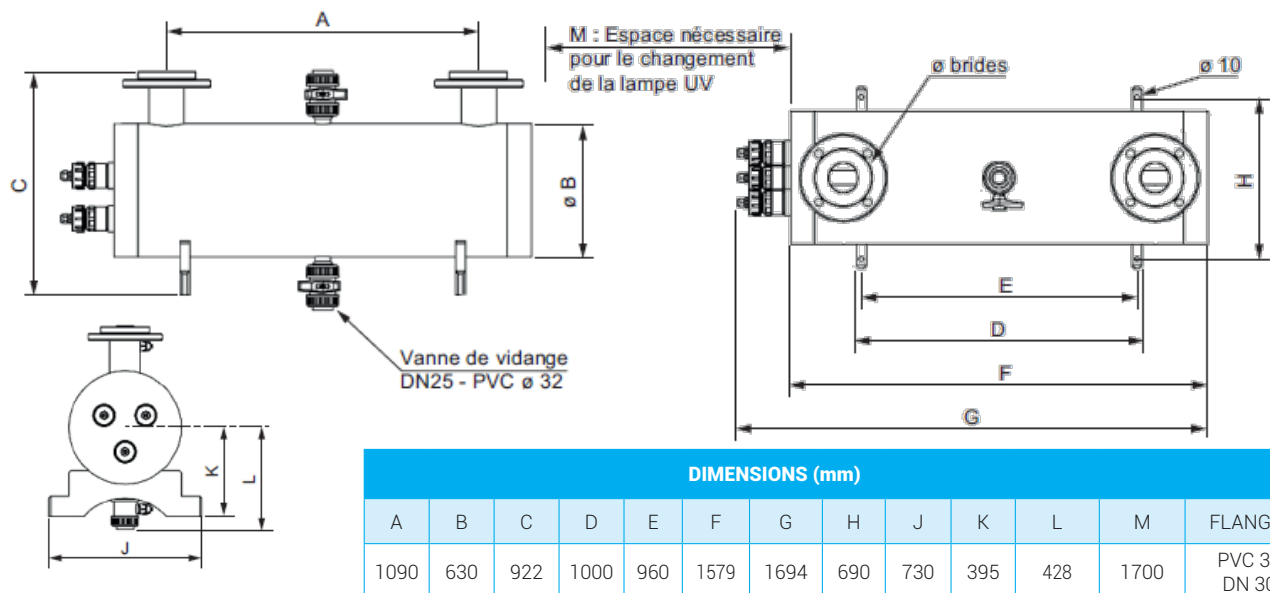

INSTALLATION

The **GERMI LD 300 HDPE** is installed on the main water supply pipe. **It should be positioned horizontally**, water entry and exit are equivalent. Sufficient space must be left beside the lamps (at least 1.7 m) or allow for easy dismantling of the unit (bypass) to replace the UV lamps.

If the reactor must be installed vertically, it must be equipped with an automatic air bleed in the upper part. If applicable, we recommend having the water enter via the bottom and exit via the top of the reactor.

The device must be protected against "water hammer" using a water hammer protection device (pressure vessel, shock absorber, etc.) if needed. It must also be protected from freezing or very hot temperatures. **We strongly recommend installing a filter upstream of the unit** to reduce the particles that might mask the UV radiation.

MAINTENANCE

Maintenance is limited to the replacement of the UV lamps and the replacement or cleaning of the sleeves. The UV lamps have a maximal service life of 16,000 hours, after which water disinfection is no longer guaranteed. The quartz sleeves protecting the lamp make lamp replacement much easier. The quartz sleeves may become clogged or deposits may form. They should be cleaned with mild acid.